



TECHNICAL SHEET

FLECK
9100 TWIN VALVE SERIE





FLECK VALVE TWIN SERIE - 9100



TECHNICAL CHARACTERISTICS

- Continuous soft water provision with only one tank in use, other being in regeneration or stand-by
- Regeneration with softened water
- Valve body in PPO, corrosion-proof
- Fast connection of the second tank, with connecting pipes in PVC delivered with the valve
- Optional : upflow regeneration

OPERATING SPECIFICATIONS

VALVE SPECIFICATIONS

Material	PPO*
Hydrostatic pressure	20 bar
Working pressure	1.8 - 8.5 bar
Working temperature	1 - 43 °C
Electrical rating	24 V / 50 or 60 Hz, other upon request
Protection index	IP 22
	2004/108/CE, Electromagnetic compatibility
Certificates	2006/95/CE, Low voltage
	D.M. 174/04, Italian norm

*PPO: Polyphenylene oxide

FLOW RATE (3.5 BAR INLET - VALVE ALONE)

	3/4 inch	1 inch
Continuous ($\Delta p = 1$ bar)	4 m ³ /h	4.5 m ³ /h
Peak ($\Delta p = 1.8$ bar)	5.4 m ³ /h	5.9 m ³ /h
Cv*	4.8 gpm	5.2 gpm
Maximum backwash ($\Delta p = 1.8$ bar)	1.9 m ³ /h	1.9 m ³ /h

* Cv: Flow rate of valve alone in gpm at 0.07 bar pressure drop.

DOWN FLOW REGENERATION

	Mechanical	Electronic
Cycles	Adjustable	Adjustable
Time available	164 min	199 min each cycle

VALVE CONNECTIONS

Inlet / outlet	¾ or 1 inch BSP
Distributor tube	26.7 mm (1 inch)
Drain line	½ inch
Brine line 1600	¾ inch
Mounting base	2 ½ inches - 8 NPSM
Height (from top of tank)	185 mm

Tank size application (recommended)

Water softener	6 - 16 inches (150 - 400 mm)
----------------	------------------------------

METER

	¾ inch	1 inch
Accuracy range (± 5%)	1 - 57 Lpm	26 - 151 Lpm
Standard capacity range	0.5 - 8 m³	1 - 20 m³
Extended capacity range	2.5 - 40 m³	5 - 100 m³

REGENERATION CYCLES

Upflow

- 1) Brine and slow rinse (Upflow)
- 2) Backwash (Upflow)
- 3) Rapid rinse (Down flow)
- 4) Brine tank refill
- 5) Service

Down flow

- 1) Backwash (Upflow)
- 2) Brine and slow rinse (Down flow)
- 3) Rapid rinse (Down flow)
- 4) Brine tank refill
- 5) Service

OPTIONS

Regeneration :	Upflow
Electronic :	ET, SXT
Mixing :	Yes
By-pass :	Valve ¾ inch

DIMENSIONS

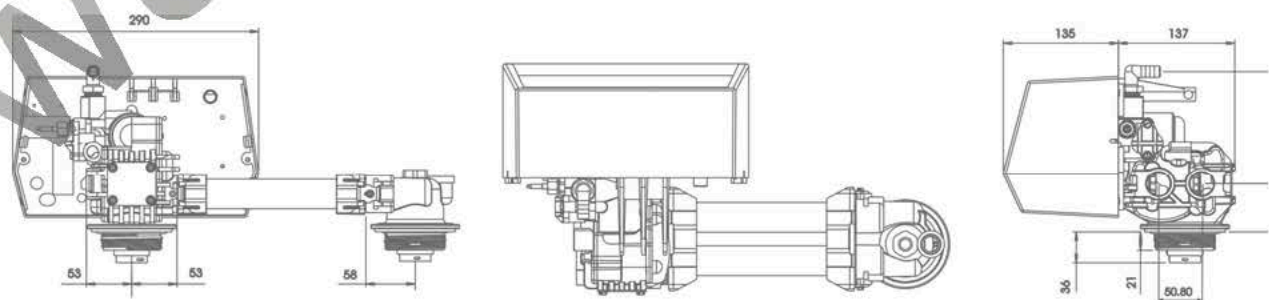



watersmarket.ru

www.pentairaquaeurope.com